

RISO *SE* 9380

Streamline your work with revolutionary print speed.



1
COLOUR
PRINTING

Accelerate your tasks.

Put the power of **185 ppm** printing to work for you.

The RISO SE9380 digital duplicator offers exceptional print quality at unrivalled maximum print speed and incredibly low cost, enabling easy and efficient large volume printing. It reproduces photographs and text with remarkable image quality and, in addition to enhanced environmental features, incorporates a variety of improved print functions.

And the highly durable SE series let you use various type of paper, making them more versatile than ever.



RISO SE 9380

The large-volume digital duplicator with unparalleled performance

High Productivity

Print more copies,
in less time, at less cost.



Unrivalled maximum print speed of 185 pages per minute.

In addition to an adjustable five-speed function for printing between 60 and 130 pages per minute, the RISO SE9380 digital duplicator has a high-speed mode that prints at a maximum speed of 185 pages per minute, the fastest in the industry, or approx. 925 pages in five minutes. A variety of documents, including meeting handouts and marketing and promotional material, can be printed in a speedy and efficient manner regardless of the required paper size.

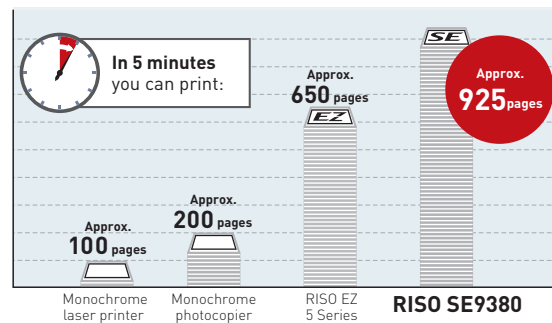

Note: Comparison of the RISO SE9380 (185 pages per minute) and RISO EZ 5 Series (130 pages per minute) digital duplicators with monochrome photocopiers [A4 size, 40 pages per minute] and monochrome laser printers [A4 size, 20 pages per minute].

The larger the job volume, the lower the operating cost.

The RISO SE9380 first creates a master copy of the original document, from which prints are made. The printing cost per copy of a document goes down with every print, making the RISO SE9380 highly economical for large-volume printing. You can use the optional "A4/letter drum" to print these popular sizes even more efficiently to save master usage, holding down running costs to a minimum.

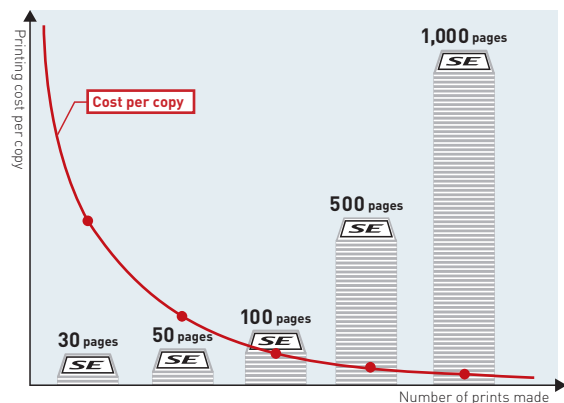

Efficiently separates the printed paper into specified lots.

The RISO Job Separator IV:NIII, an optional feature on the RISO SE series, enables tape to be inserted between printing jobs even during high-speed printing and speedily separates the printed paper into lots of specified numbers, all without interrupting the printing process.



Notes: The Receiving Tray Paper Guide must be changed in the RISO Job Separator IV: NIII high-speed mode. The RISO Job Separator IV:NIII high-speed mode is not available with the RISO Auto-control stacking tray.

High Quality

Sharp, rich images give your ideas impact on the page.

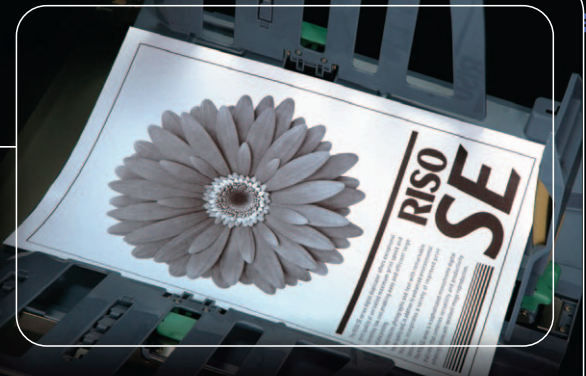

High-resolution 600 dpi scanning and printing gives clear output.

The RISO SE9380 digital duplicator both scans and prints information at a high resolution level of 600 dpi, producing sharp, clear images of even fine lines and small characters. The model uses the RISO Master E Type HG, with a two-layer ink-permeable sheet adding an extra fine-filter layer to the standard layer, enabling even ink transfer to the paper. It can also reproduce subtle colour gradations, enabling users to print clear copies of photos, shaded areas of images, and documents written in pencil.

RISO Master E Type HG cross-section

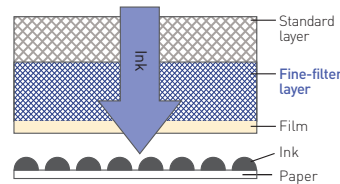

Magnified view of master

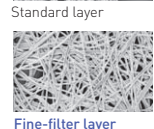
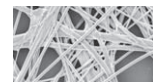

Unique technology for uniform, solid images.

The RISO SE9380 model uses a pre-suction mechanism in which air is passed between the paper and the print drum to suck the paper in a downward direction, thus separating it instantaneously from the drum before it is output. This original technology allows the ink to be transferred uniformly to the paper to produce clear images.

Pre-suction mechanism

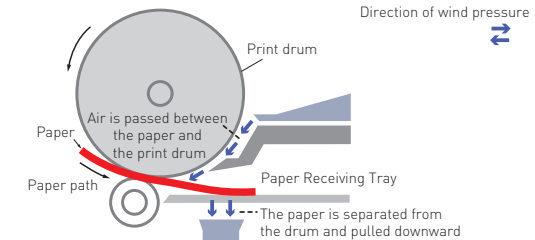

A rainbow of variety for your work.

The machine's colour drum accommodates a wide variety of inks in 21 standard colours, 50 custom colours, plus special order-made colours that can give corporate logos an extra-special look. This huge selection of colours lets you add powerful impact to your documents. And because the ink is made by RISO, you're assured of the highest quality results. Front panel access makes switching the drum quick and easy to change colour, too.

Red	Bright Red	RISO-Marine Red	Burgundy
Brown	Yellow	Green	Teal
Blue	Medium Blue	RISO-Fed. Blue	Purple
Flat Gold	Orange	Crimson	Hunter Green
Gray	Light Gray	Fluorescent Pink	Fluores. Orange
		Gold	

[Custom colours]



Note: The actual colours may differ from the samples shown above.



Adjusting brightness for optimal photo-quality images.

Choose the image-processing mode setting best suited to the original photo or document. Choose Duo mode for documents that are a mix of text and photos, process only the photos and print out crisp images with clear text.



Photo mode: Portrait



Photo mode: Group



Pencil mode

Ease of Operation

Controls designed with ease of use in mind.



Print from hard copies, a computer, a USB drive, or stored data.

The RISO SE9380 digital duplicator can be connected to a network, so original data and settings can be sent from a remote PC. Even if the printer is not connected to your PC or network, you can still print directly from your data file. Just save the file to a USB flash drive, connect the flash drive to the printer via the built-in USB port, and you're ready to print. And of course you can print from copies scanned directly into the unit.

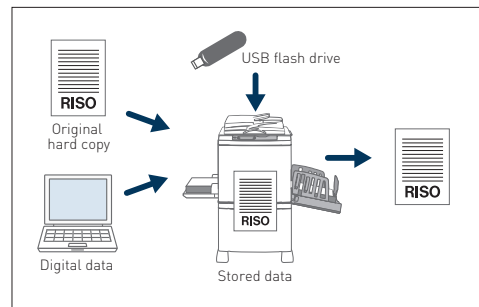

A large display for easy editing of your document.

The large, interactive touchscreen display panel enables easy default settings and operation. The visibility of the LCD panel can be enhanced through colour reversal or by adjusting the contrast setting. The original document, whether paper or digital data, can be saved in the Storage folder, displayed on the touchscreen, and checked. The RISO Editor enables easy image processing and separation of text blocks and images. The information displayed can be magnified, allowing detailed checking of the content.



Touchscreen display panel



The layout function saves paper by consolidating information on a single page.

With "Multi-up" function, documents that run into several pages can be consolidated into fewer pages and in an easier-to-read format, thus reducing the amount of paper required for printing.

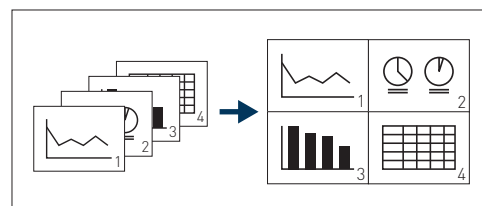

Eco-friendly Operation

The same performance,
with lower environmental impact.



RISO dedication to a greener tomorrow.

RISO is proud to recognize its responsibility as a member of the global community. Our basic philosophy is to contribute to society through the development of excellent products. We endeavour to contribute to global environmental protection to preserve a healthy, sound environment for the coming generations.



Recycled parts

Ink bottles and some parts for the SE series are made partially from recycled components.



ENERGY STAR® Program

Compliant with an international program that promotes energy saving in printing machines. The program sets standards in terms of the power consumption of printing machines.



RoHS Directive

Compliant with the European Union directive on the restriction of the use of certain hazardous substances in electrical and electronic equipment.



Energy-efficient printing

The digital duplicator uses no toner and therefore needs no source of heat to affix the toner in the print process. Turn the duplicator on and it's ready to go in an instant, letting you save energy whenever it's not in use. And high-speed printing means your job is done sooner, so you can turn it off that much more quickly.



RISO Ink is made of eco-friendly soy oil

One of the ingredients of RISO INK is soy oil, making it a high-quality, eco-friendly product. It meets the soy oil content standards specified by the American Soybean Association and is certified to use the "CONTAINS SOYOIL" trademark.

Note: Order-made colours may not be available in soy-oil-based inks.

The environment-friendly functions.

The SE series comes with "Eco-mode" functions that let you turn down the control panel brightness and pressure in the press unit. Eco-mode can reduce electricity consumption by up to 2%.

Power down the unit at a fixed time with the "Auto Power-Off" function or save energy with the "Auto Sleep" function that puts the unit into a sleep mode until network activity brings it back online.



Eco-mode off



Eco-mode on

Smart, easy, and versatile: Your printing the way you want it.

Full expandability to give you the functions you need.



Auto document feeder AF-VI:II
Automatic feed of up to 50 sheets of originals.



Auto document feeder DX-1
Automatic scanning of both sides of originals and automatic feeding. 50-sheet capacity.



Card feed kit
Allows use of thicker stock such as cards and envelopes.



RISO Key card counter IV: N
Helps manage costs by showing number of copies printed and masters used in a given time period.



Job Separator IV:NIII
Allows the machine to print and sort into groups separated by tape.



RISO Auto-control stacking tray
The paper guides automatically open out to suit the paper size.

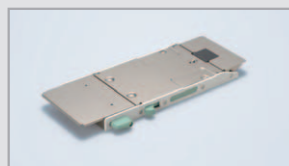

Envelope feeder
Compatible with paper weight 50 gsm to 120 gsm.
*Please contact a RISO sales executive for the kinds of envelope that may be used.



RISO controller IS300
Provides compatibility with Adobe® PostScript®3™.



Colour drum
A wide variety of colours is available. Drums can be stored in their own cases.

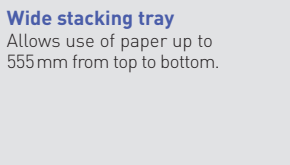

Wide stacking tray
Allows use of paper up to 555 mm from top to bottom.



Document storage card DM-128CF/DM-512CF
Allows storage of frequently used documents for instant recall.

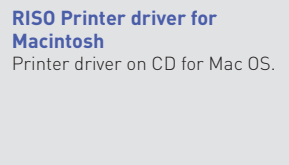

RISO Printer driver for Macintosh
Printer driver on CD for Mac OS.



RZ stand D type
Deluxe stand with doors for convenient storage with a neat appearance.



RISO stand N type
Sturdy open-front stand also offers convenient storage of consumables.

RISO Accounting tool
Printing management utility software for Windows®.

A complete range of RISO SE Series supplies.



RISO Ink
You can choose from 21 standard colours, 50 custom colours, or an unlimited number of special order-made colours—ideal for applications such as specific corporate colours.

Ink
RISO INK ETYPE HD BLACK
RISO INK ETYPE COLOR

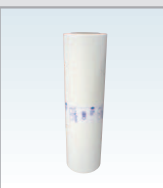

RISO Master
High-quality RISO masters provide the best performance match with SE series printers, giving a sharp, clear image to all your documents.

Master
RISO MASTER ETYPE HG 97
RISO MASTER ETYPE HD 87

RISO iQualitySystem™

The RISO iQuality System™ offers a large number of quality and convenience benefits.

Among them are:

- Automatic assurance of optimum print quality.
- Prevention of operator error.
- Warning of shortages in remaining ink/master volume.
- Minimised paper waste.



The RISO iQuality mark indicates a RISO product compatible with the RISO iQuality System.

RISO SE 9380

Specifications are subject to change without notice. Details may vary depending on the region.

- *1 When installed with RISO Auto document feeder DX-1.
- *2 When installed with RISO Auto document feeder AF-VI:II.
- *3 When installed with RISO Auto-control stacking tray.

Note: All dimensions are when installed with RZ stand D type.

■Dimensions (mm)

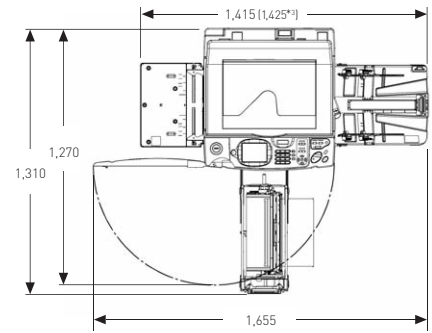
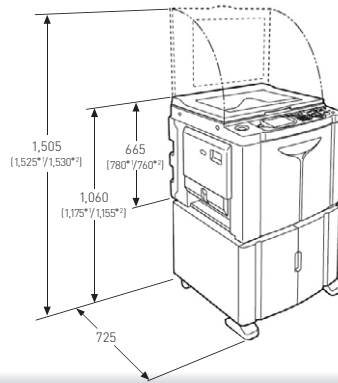

RISO SE9380 Specifications

Master-making/printing methods	High-speed digital master-making/full automatic stencil printing
Original Type	Book (10 kg (22 lb) or less), sheet
Resolution	Scanning resolution: 600 dpi × 600 dpi Printing image resolution: 600 dpi × 600 dpi
Original Size (min./max.)	When using the Glass Platen: 50 mm × 90 mm (1 ³¹ / ₃₂ " × 3 ¹⁷ / ₃₂ ") - 310 mm × 432 mm (12 ⁷ / ₃₂ " × 17") When using the Auto Document Feeder AF-VI:II (option): 100 mm × 148 mm (3 ¹⁵ / ₁₆ " × 5 ¹³ / ₁₆ ") - 310 mm × 432 mm (12 ⁷ / ₃₂ " × 17") When using the Auto Document Feeder DX-1 (option): 105 mm × 128 mm (4 ¹ / ₈ " × 5 ¹ / ₃₂ ") - 297 mm × 432 mm (11 ¹ / ₁₆ " × 17")
Original Paper Weight	When using the Auto Document Feeder AF-VI:II (option): 50 gsm (13-lb bond) - 128 gsm (34-lb bond) When using the Auto Document Feeder DX-1 (option): Single-sided feeding: 40 gsm (11-lb bond) - 128 gsm (34-lb bond) Duplex-sided feeding: 52 gsm (14-lb bond) - 105 gsm (28-lb bond)
Printing Paper Size (min./max.)	100 mm × 148 mm (3 ¹⁵ / ₁₆ " × 5 ¹³ / ₁₆ ") - 320 mm × 432 mm (12 ¹⁹ / ₃₂ " × 17")* *Paper up to 555 mm (21 ⁷ / ₃₂ ") from top to bottom may be used in the Extended Paper mode.
Paper Supply Capacity	Approx. 1,000 sheets (80 gsm (21-lb bond)) /Maximum Height 110 mm (4 ¹¹ / ₃₂ ")
Paper Receiving Capacity	Approx. 1,000 sheets (80 gsm (21-lb bond)) /Maximum Height 110 mm (4 ¹¹ / ₃₂ ")
Printing Paper Weight	46 gsm (12-lb bond) - 210 gsm (110-lb index)
Image Processing mode	Line, Photo (Standard/Portrait/Group), Duo (Line/Photo/Shadow off), Pencil (Darker/Lighter)
Master-making Time	Approx. 20 seconds (for A4/short edge feed/100% reproduction ratio) Approx. 16 seconds (for A4/long edge feed/100% reproduction ratio)
Printing Area (max.)	291 mm × 413 mm (11 ¹⁵ / ₃₂ " × 16 ¹ / ₄ ")
Print Reproduction Ratio	Zoom: 50 - 200% Standard reproduction ratio (enlargement): 163%, 141%, 122%, 116% Standard reproduction ratio (reduction): 87%, 82%, 71%, 61% Margin+: 90 - 99 %
Print Speed	60 - 130 sheets per minute (control panel: five steps variable) 180 - 185 sheets per minute (Touch panel: "High Speed")
Print Position Adjustment	Vertical: ±15 mm (± ¹⁹ / ₃₂ ") Horizontal: ±10 mm (± ²⁵ / ₆₄ ")
Ink Supply	Fully automatic (1,000 ml per cartridge)
Master Supply/Disposal	Fully automatic (approx. 220 sheets per roll)
Master Disposal Capacity	100 sheets
User Interface	LCD Touch Panel with Progress Arrow indicators
Operating Noise	Max. 66 dB(A) (when printing 100 sheets per minute)
Power Source	SE9380A: AC 100-240 V, 50-60 Hz <5.0-2.2 A> SE9380E: AC 220-240 V, 50-60 Hz <2.2 A>
Power Consumption (without option)	Max. 400 W (100 V)/380 W (220 V) At Ready: approx. 43 W (100 V)/43 W (220 V) At Sleep: approx. 2.0 W (100 V)/3.0 W (220 V)
Functions	Idling, Print Speed Adjustment, Silent mode, Confidential mode, Auto-Process, Job Memory, Ink Saving, Layout, Binding Margin, Reservation, Output Reversal, Proof, Double Feed Check, User Management, Management of Consumables, Contrast Adjustment, Print Density Adjustment, Print Position Adjustment, Tone Curve, Jump Wing Control, Top Margin, Paper Size detection, Renew Page, Dot Process (4 types), Preview, Rotate, Scanning Side (with optional ADF DX-1), Admin. Mode, Interval Printing, Max. Scan, Special Paper Control, Auto 90° Rotation, Protect, Paper Size Selection, Overlay (with optional memory card or USB Flash Drive), Direct Print, Storage memory (with optional memory card), Scan Mode (with optional memory card or USB Flash Drive), My Direct Access, ID Counter Report, USB Job List (with USB Flash Drive), Custom Paper Entry, Programmed Printing (2 types), Direct Access Entry, Selections Entry, Book Shadow, RISO i Quality System, Scanning Contrast (Manual/Auto), Multi-Up Print (2 up/Single-Original/Multiple-Original/Multi-Up Tickets), ADF Semi-Auto (with optional ADF unit installed), Energy Saving Mode (Auto Sleep, Auto Power-OFF), ECO Mode
Dimensions	When in use: 1,415 mm(W) × 705 mm(D) × 665 mm(H) [55 ²³ / ₃₂ "(W) × 27 ³ / ₄ "(D) × 26 ³ / ₁₆ "(H)] When in storage: 780 mm(W) × 705 mm(D) × 665 mm(H) [30 ²³ / ₃₂ "(W) × 27 ³ / ₄ "(D) × 26 ³ / ₁₆ "(H)]
Required Space*1	1,655 mm (W) × 1,310 mm (D) × 1,505 mm (H) [65 ⁵ / ₃₂ " (W) × 51 ⁹ / ₁₆ " (D) × 59 ¹ / ₄ " (H)]
Weight*2	Approx. 115 kg (254 lb)
Safety Standard	IEC-60950-1 compliant, Indoor, pollution degree 2*3, At altitudes of 2,000 m or lower

Note: • Please note that due to improvements and changes to the machine, some images and explanations in this manual may not correspond to your machine.
• The specifications are subject to change without prior notice.

*1 The height includes the height of the RZ stand D type.

*2 The weight does not include Ink and Master.

*3 The pollution degree of the usage environment due to dirt and dust in the air. Degree "2" corresponds to general indoor environment.

RISO logo, RISO i Quality System™ and  are either registered trademarks or trademarks of RISO KAGAKU CORPORATION. Adobe and PostScript are either registered trademarks or trademarks of Adobe Systems Incorporated in the United States and/or other countries. Mac OS is a trademark of Apple, Inc. Windows is either a registered trademark or trademark of Microsoft Corporation in the United States and/or other countries.



RISO KAGAKU CORPORATION
<http://www.riso.com/>

For more details please contact: